

dCS Paganini Menu Guide

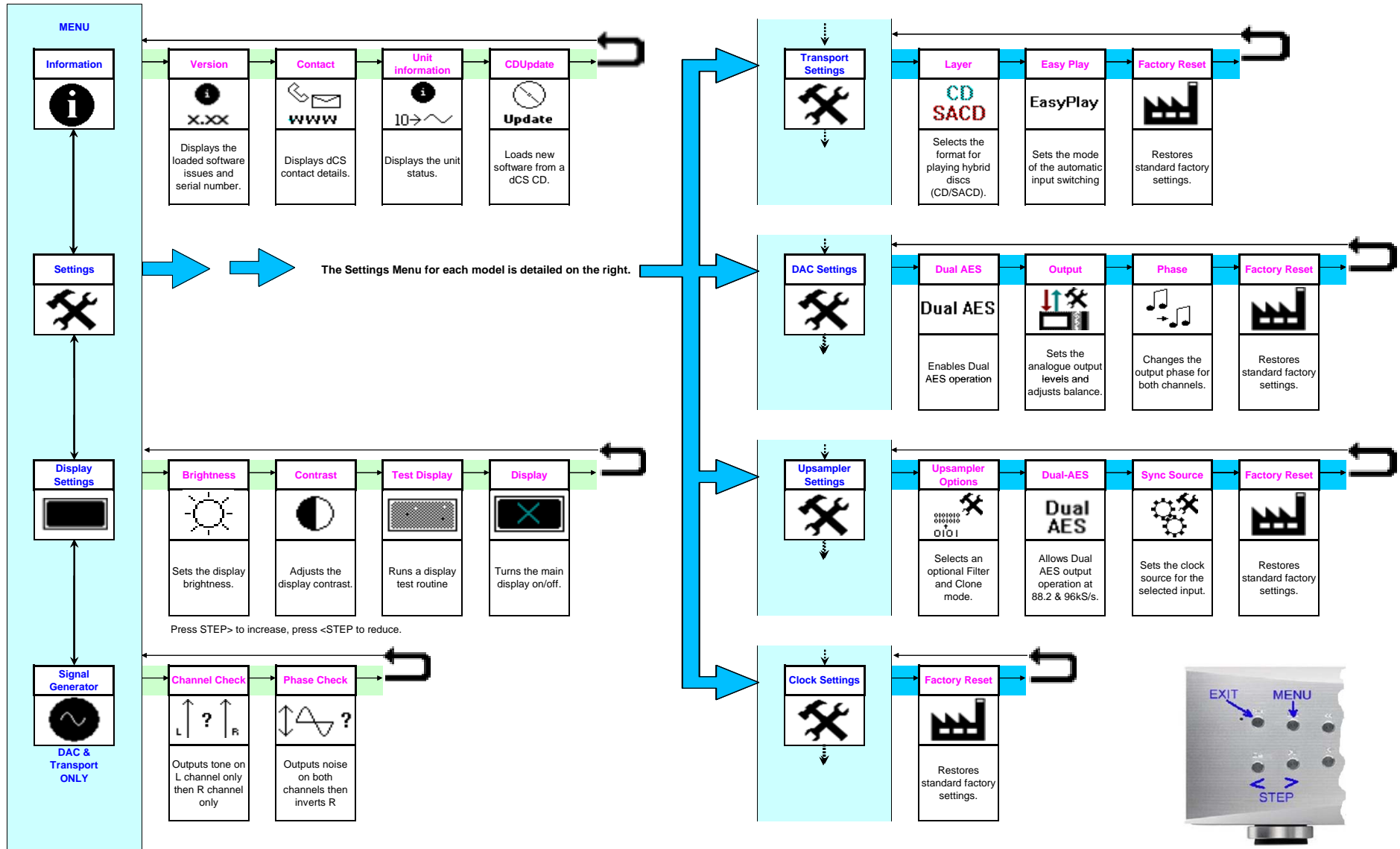

Press the MENU button to open the menu, the EXIT button to close it.
The STEP > button moves along the menu, the STEP < button moves back.
Press the MENU button to set a menu option or change options.

Paganini setup without a Clock

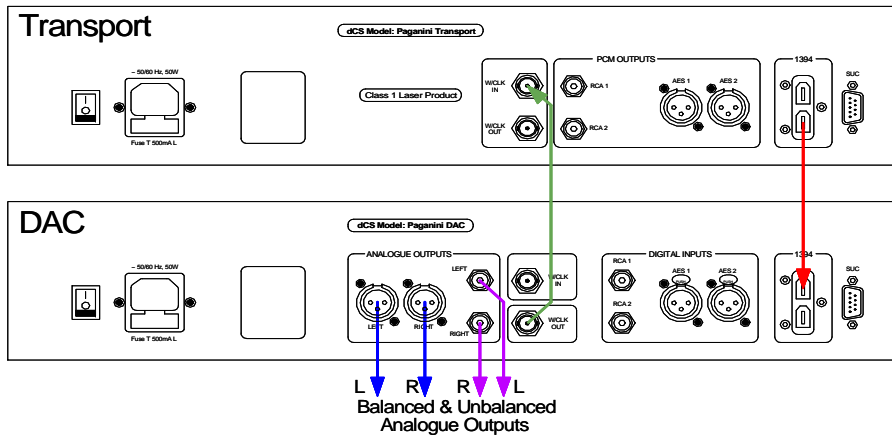

CONNECTIONS

Connect the DAC's Balanced or Unbalanced **Analogue Outputs** to the inputs of the preamplifier or power amplifier.
 Connect a 1394 cable from the Transport to the DAC.
 Connect a BNC cable from the DAC's **WCLK Output** to the Transport's **WCLK Input**.

DAC SETTINGS

Use the **INPUT** button to select the **1394** input, **PTT** channel.
 Use the **SYNC** button to set the unit to **Master** mode.
 Use the **FILTER** button to choose a filter (usually **Filter 1** in DSD mode).

The Paganini Upsampler Manual contains advice on setting up a 4-box system.

Paganini setup including a Clock

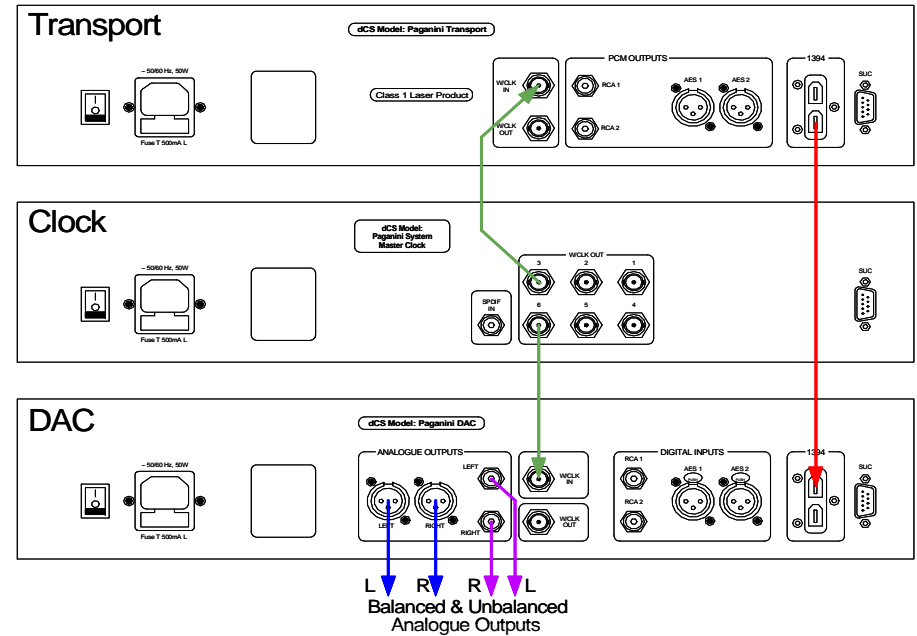

CONNECTIONS

Connect the DAC's Balanced or Unbalanced **Analogue Outputs** to the inputs of the preamplifier or power amplifier.
 Connect a 1394 cable from the Transport to the DAC.
 Connect a BNC cable from a Clock **WCLK Output** to the Transport's **WCLK Input**.
 Connect a BNC cable from a Clock **WCLK Output** to the DAC's **WCLK Input**.

DAC SETTINGS

Use the **INPUT** button to select the **1394** input, **PTT** channel.
 Use the **SYNC** button to set the unit to **WCLK** mode.
 Use the **FILTER** button to choose a filter (usually **Filter 1** in DSD mode).

CLOCK SETTINGS

Use the **FREQUENCY** button to select **44.1kHz**.
 Use the **DITHER** button to turn dither on or off as you prefer.