

dCS Debussy DAC
**Stereo Digital to Analogue Converter
with asynchronous USB Interface**

User Manual
Software Release 1.0x
June 2010

© Data Conversion Systems Ltd. 2010

Price UK £8.00 / Euro 12.00

All rights reserved. No part of this publication may be reproduced, stored in or introduced into a retrieval system, or transmitted in any form, or by any means (electronic, mechanical, photocopying, recording or otherwise) without the prior written permission of *dCS*¹. Any person who does any unauthorised act in relation to this publication may be liable to criminal prosecution and civil claims for damages.

Information contained in this manual is subject to change without notice, and whilst it is checked for accuracy, no liabilities can be accepted for errors.

¹ *dCS* is Data Conversion Systems Ltd. Company registered in England No. 2072115.

Contents

Using the dCS Debussy DAC for the first time.....	4
What's in the box?	4
Positioning the unit	4
Safety Notice	5
Patent Pending	5
Step-by-Step Guide	6
Preliminaries	6
Fitting the Remote Control handset batteries	7
STEP 1 – Selecting a Digital Input	8
Connecting the USB interface	8
Connecting to a Single AES or SPDIF source	9
Connecting to a Dual AES Source	10
STEP 2 – Setting up the USB source	11
A word about Music Playing Software	11
Selecting the <i>Debussy DAC</i> as your Audio Output device	11
STEP 3 – Connecting the Analogue Outputs	12
Using a preamplifier	12
Using a power amplifier directly	12
STEP 4 – Using a System Clock	13
Front Panel.....	14
POWER Button	14
VOL+/- Buttons	14
MUTE Button	14
FILTER Button	14
PHASE Button	15
INPUT button	15
Word Clock Indicator	15
Remote Control Receiver	15
Input Indicators	16
Sample Rate Indicators	16
Factory Reset	16
Rear Panel	17
Analogue Outputs	17
Output Level Switch	17
AES Digital Inputs	17
SPDIF Digital Inputs	17
Word Clock Input	17
USB Interface	18
Label	18
TEST Connector	18
Mains inlet	18
Remote Control.....	19
Specification	20
Maintenance and Support.....	21
Service and Maintenance	21
Replacing a Blown Mains Fuse	21
Cleaning the case	21
Limited Warranty	22
Software	23
Which Software Issue is loaded?	23
Updating the Software	23
Software History	24
If you need more help	24

USING THE *dCS Debussy DAC* FOR THE FIRST TIME

Congratulations on purchasing your *dCS Debussy DAC*.

Before using your unit, please read this section and the Step by Step Guide. This will enable you to set the unit up quickly and safely with your hi-fi system.

From time to time, *dCS* may release updated software you can install yourself from a PC. Please check our web-site occasionally to see if new *Debussy DAC* software is available, or consult your dealer.

What's in the box?

Check that the box contains the following items:

- *dCS Debussy DAC*
- Manual
- Power cable
- USB cable
- 2 spare fuses
- *dCS* Premium Remote Control with 2x AAA batteries

Notify your dealer as soon as possible if anything is missing or damaged. We suggest that you retain the original packaging for possible future use. If this is not possible, replacement packaging can be ordered from *dCS* or our distributors. Details can be found on our web site at www.dcsLtd.co.uk.

The cables supplied are commercial-grade parts, as we realise our customers will want to make their own choices.

Positioning the unit

The *Debussy DAC* may be stacked with other products, but the system is likely to give better sonic results when units are mounted on separate shelves of a rack. Place each unit on a firm, vibration free base, allowing convenient connection to the other parts of your system. To prevent overheating, we recommend that you leave some free space around the unit to allow for ventilation.

3 feet are fitted as standard, this may be changed to the 4-foot arrangement shown below, if you prefer. Spare feet are available as an optional extra. The mounting points are M4 size, maximum screw depth is 8mm.

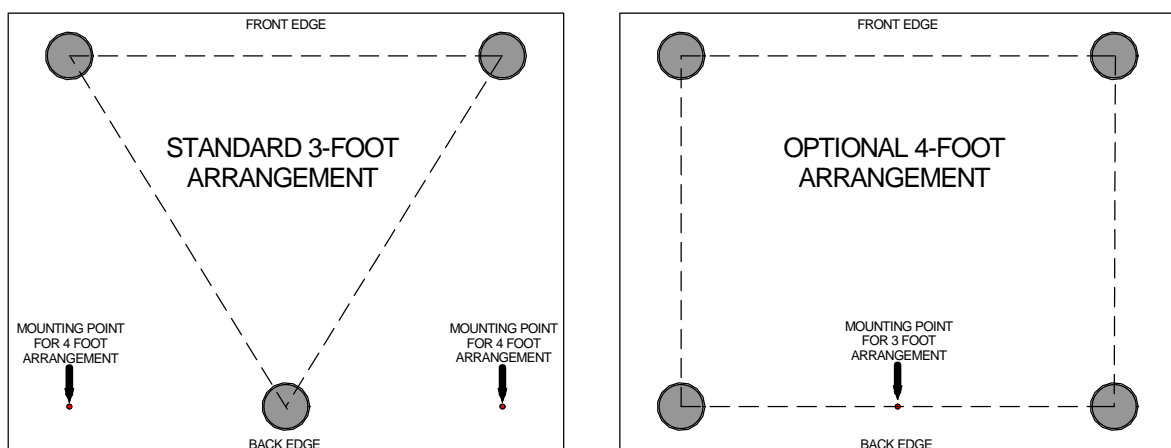

Safety Notice



Your *dCS Debussy DAC* contains no user serviceable parts. **DO NOT** attempt to open the case as there are potentially dangerous voltages present inside. In the event of the unit developing a fault, please contact your dealer in the first instance.

To maintain protection from electric shock, the unit **MUST** be connected to mains earth (ground) via the power cable. Also, unearthed systems do not give the best sonic performance.



This product is lead-free to comply with the RoHS directive.

Before connecting the power cable to the unit for the first time, please check that it has been set to the correct operating voltage for your mains supply. The unit's voltage setting is shown on the serial number label. If this does not match your local supply voltage, **DO NOT** attempt to use the unit. Contact your dealer to have the unit reset. Using the unit with the wrong mains setting for your local supply may result in serious damage to the unit and will invalidate the warranty. Do not attempt to reset the voltage yourself.

We do not recommend the use of mains regenerators. However, if you do wish to use a mains regenerator with variable voltage and frequency, we recommend that you set the voltage to match your local voltage and the frequency to either 50Hz or 60Hz **ONLY**.



Damage caused to your *Debussy DAC* by misuse of a mains regenerator or by a malfunctioning mains regenerator is not covered by the warranty.



Disposal at end-of-life - the symbol indicates that this product should not be treated as normal household waste. It should be recycled, so please take it to an approved collection facility.

Patent Pending

This product contains novel features that are the subject of patent application GB0817141.5.

STEP-BY-STEP GUIDE

This section guides you through setting up the unit for basic operation.

Preliminaries

For digital interfaces, use with cables designed for digital audio:

- for AES/EBU interfaces use 110Ω screened, twisted pair cables fitted with one male 3-way XLR connector and one female 3-way XLR connector.
- for SPDIF BNC and Word Clock interfaces, use 75Ω coax cables fitted with BNC plugs.
- for SPDIF RCA interfaces, use 75Ω coax cables fitted with RCA Phono plugs.
- for the USB interface, use a standard screened USB cable fitted with one type 'A' connector and one type 'B' connector. The internal screen must be connected at both ends.

For analogue outputs, use with screened cables of the correct type:

- for balanced outputs, use screened, twisted pair cables fitted with one male 3-way XLR connector and one female 3-way XLR connector.
- for unbalanced outputs, use coax cables fitted with RCA Phono plugs.

Connect the power cable supplied to the power inlet on the *Debussy DAC* rear panel, plug the other end into a convenient power outlet.



If you wish to use a power cable other than the one supplied, please ensure that it is a good fit to the mains inlet, and is not so heavy or inflexible as to place strain on the mains inlet.

Set the rear panel power switch to the **I** position, press the **POWER** button briefly and wait about 30 seconds while the unit configures itself. The Power indicator and one or two of the input indicators will illuminate, some of the other indicators may also illuminate.

Fitting the Remote Control handset batteries



Use a small coin to release the screw securing the back plate.

Lift the screw a little and slide the back plate off.

Fit 2 AA size batteries by pressing the flat end (-) against the spring and pressing the battery into the slot, so that the + end makes contact with the stud.

Slide the back plate into place and tighten the screw.



Failure to fit the batteries correctly can damage your Remote Control. Such damage is not covered by the warranty.



Please dispose of used batteries properly at a waste disposal site, not in the household waste.

STEP 1 – Selecting a Digital Input

Switch on the source equipment. If appropriate, load a disk / tape and set the machine in PLAY mode to ensure it is generating a digital audio data stream. Choose one or more of the following sections:

Connecting the USB interface

The USB interface can be connected to Windows™ Vista / 7 or Windows™ XP (SP2 or later) PC, Mac™ OSX (10.5.4 or later) systems or a sound server, running software to generate PCM data.

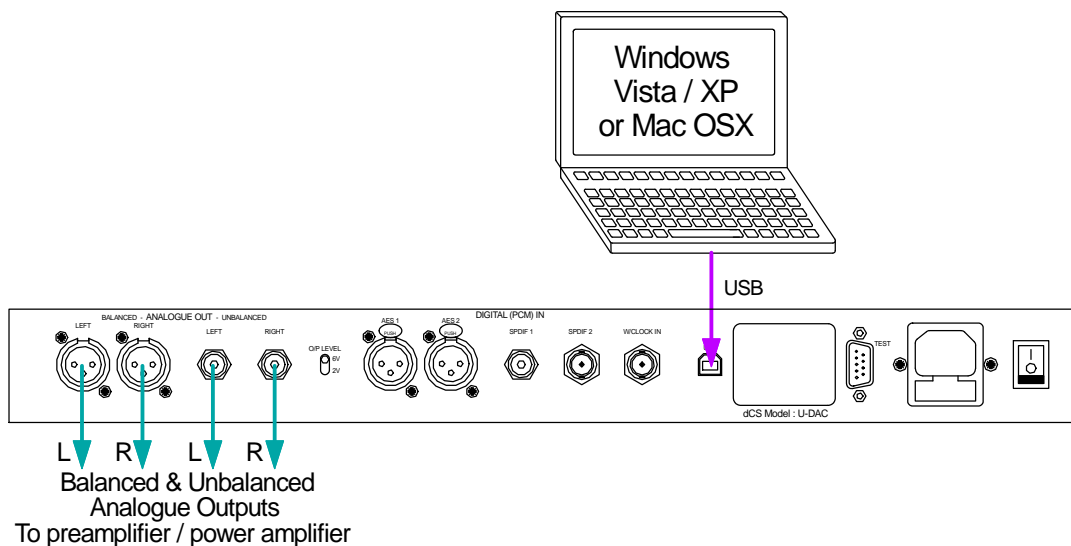

Figure 1 – Connecting the USB interface.

- Connect one of the computer's USB ports to the **USB** port on the *Debussy DAC* rear panel.
- Press the **Input** button repeatedly until the **USB** input indicator is lit. If the source is transmitting PCM data, the *Debussy DAC* will lock to the source and the appropriate sample rate indicator will illuminate.

The *Debussy DAC*'s USB interface operates in asynchronous mode. This allows the clock inside the *Debussy DAC* to control the delivery of data from the computer, avoiding the use of the computer's inaccurate and jittery clock.

Proceed to Step 2.

Connecting to a Single AES or SPDIF source

Most source equipment (such as a CD transport or DVD player) is fitted with a single wire digital output, usually on an RCA phono connector.

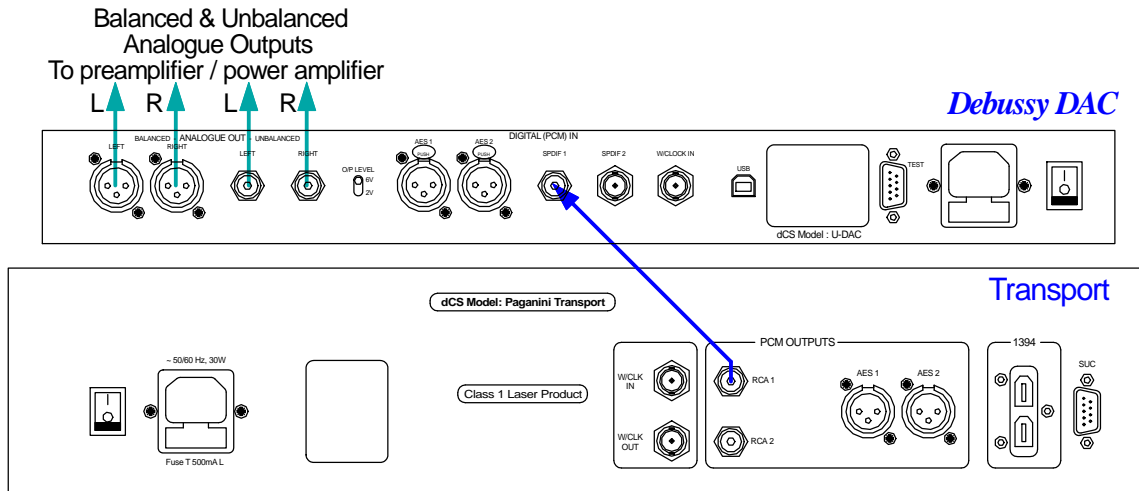

Figure 2 – Connecting an SPDIF interface.

- Connect your source equipment to the matching input on the **Debussy DAC**'s rear panel using a suitable cable.
- Press the **Input** button repeatedly until the **AES1**, **AES2**, **RCA1** or **RCA2** indicator illuminates as required.

If the source is active, the **Debussy DAC** will lock to the source and the appropriate sample rate indicator will illuminate.

Proceed to Step 3.

Connecting to a Dual AES Source



For Dual AES mode to work correctly, the source must actually generate Dual AES data, not just single AES on 2 connectors (which gives a mono output)!

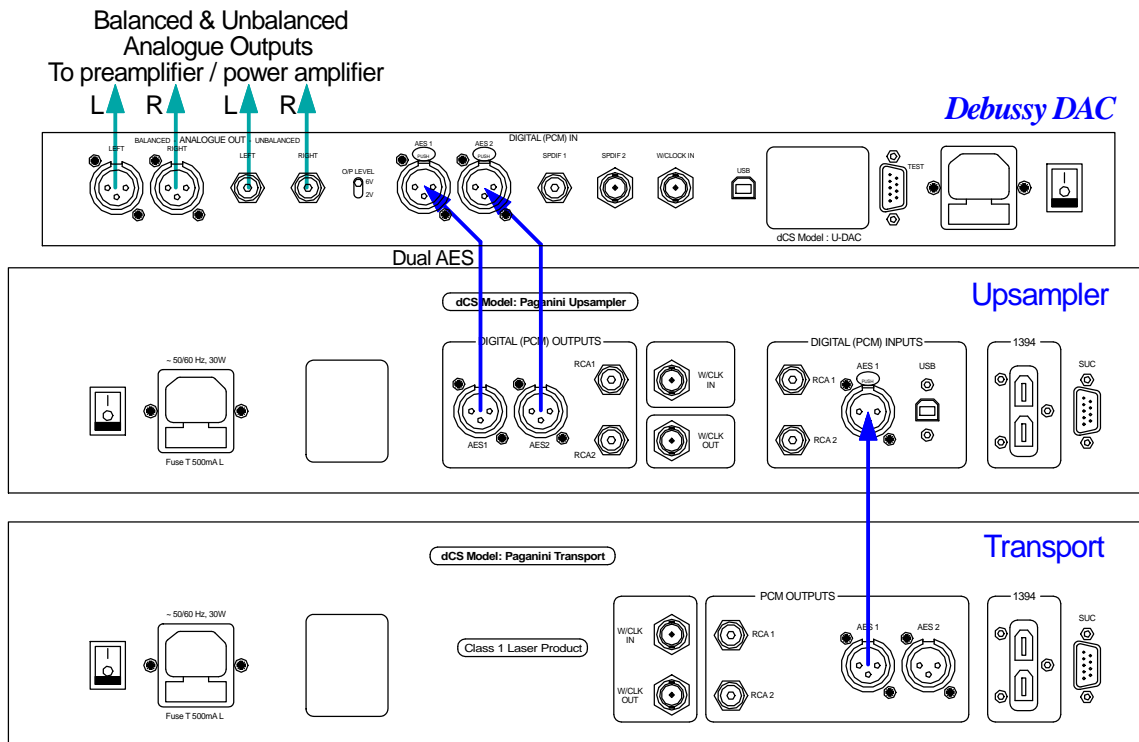

Figure 3 – Connecting the Dual AES interface.

- Connect the AES1 (or AES A) output on your source equipment to the **AES1** input on the *Debussy DAC's* rear panel and the AES2 (or AES B) output to the **AES2** input, using two XLR cables. Ensure the cables are not swapped.
- Press the **Input** button repeatedly until the **AES 1** and **AES 2** input indicators illuminate. If the source is active, the *Debussy DAC* will lock to the source and the appropriate sample rate indicator will illuminate.

Proceed to Step 3.

STEP 2 – Setting up the USB source

If you do not want to use a USB source, go to STEP 3.

A word about Music Playing Software

There are countless programs that can play music on Windows™ PC and Apple Mac™ OSX systems. Unfortunately, not all of them present the data completely unprocessed to the USB ports. For example, Windows Media Player re-samples all data to 24 bits, albeit at the original sample rate, whilst iTunes rate converts data as necessary to the output sample rate set in the OSX Audio set-up panel.

With such a proliferation of playing software, and with updates being issued daily, it is impossible for dCS to be fully up-to-date with the behaviour and performance of all programs. If you have questions or problems, we would urge you to take them up with your software vendor. What we will say is that different programs operate very differently and it is well worth finding out exactly how your particular program processes the audio.

One particular problem that has been identified and is worthy of note, concerns the popular iTunes program when running on Windows systems. The default output word length is 16 bits and must be changed to 24 bits for correct operation. To do this, click on **Start > Control Panel > Quicktime**. Click on the **Audio** tab of the Quicktime panel and select **24 bit** in the **Size** field of the **Sound Out** section.

Selecting the Debussy DAC as your Audio Output device

Whichever program you are using to play your music, your computer may not automatically select your *Debussy DAC* as the preferred playback device. You can correct this as follows :

Windows XP™ - Once you have connected the *Debussy DAC* and switched it on, go to **Start > Control Panel > Sounds and Audio devices**. Click on the **Audio** tab and select **dCS Debussy** from the drop down list in the **Sound Playback - Default Device** list. For best results, set the **Sample Rate** to be the same as that of the file.

Windows Vista™ / Windows 7™ - Once you have connected the *Debussy DAC* and switched it on, go to **Start > Control Panel > Hardware and Sound > Sound** and click on the **Playback** tab of the panel that appears. Select **dCS Debussy** from the list of available devices. For best results, click on **Properties > Advanced** and set the **Default Format** to 24 bits at the same sample rate as that of the file.

Mac™ OSX - Once you have connected the *Debussy DAC* and switched it on, open **Finder**, click on the **Go** tab and select **Utilities**. In the Utilities panel, select **Audio MIDI Setup** and click on the **Audio Devices** in the Audio MIDI setup panel. Select **dCS Debussy** from the drop down list in the **System Output**. You can also set **dCS Debussy** as the default output from the same panel. For best results, set the **Sample Rate** to be the same as that of the file.

For more detailed advice, please visit www.dcsLtd.co.uk/page/support and download the “**dCS Guide to Computer Audio**”.

Go to STEP 3.

STEP 3 – Connecting the Analogue Outputs



The output level relays can flip over in transit, resulting in one or both channels having a lower or higher level than expected. This can be corrected by changing the **O/P Level** switch setting then changing back.

The balanced and unbalanced outputs are separately buffered, you can connect both to different amplifiers at the same time if required. Choose one of the following two sections:

Using a preamplifier

- Set the preamplifier volume control to minimum.
- Connect either the balanced (XLR connectors) or unbalanced (RCA phono connectors) outputs on *Debussy DAC's* rear panel to matching line level inputs on your preamplifier (probably labelled CD or AUX).
- Hold down the *Debussy DAC's* **Vol+** button for 10 seconds to set the Volume to maximum. This is indicated by all 7 Sample Rate LEDs illuminating for 5 seconds (see **Figure 4**).
- While playing some music, increase the preamplifier volume until the music is at the desired level.
- If the preamplifier volume setting for a comfortable listening level is too high or too low, you may need to change the setting of the **O/P Level** switch on the back panel.



Setting the **O/P Level** to **6V** can cause some preamplifiers to overload and distort. For this reason, we recommend the **2V** setting if a preamplifier is used.

Using a power amplifier directly

- Hold down the *Debussy DAC's* **Vol-** button for 10 seconds to set the Volume to minimum. This is indicated by all 7 Sample Rate LEDs turning off for a few seconds (see **Figure 4**).
- Connect either the balanced (XLR connectors) or unbalanced (RCA phono connectors) outputs on the *Debussy DAC's* rear panel to matching inputs on your power amplifier. Switch on the power amplifier.
- While playing some music, hold down the *Debussy DAC's* **Vol+** button until the music is at the desired level. You will see the Sample Rate indicators illuminate from the bottom as the volume increases.

	Minimum Volume	Volume set between -10 and -20dB	Maximum Volume (0dB)
0dB	<input type="radio"/> 32	<input type="radio"/> 32	<input checked="" type="radio"/> 32
-10dB	<input type="radio"/> 44.1	<input type="radio"/> 44.1	<input checked="" type="radio"/> 44.1
-20dB	<input type="radio"/> 48	<input checked="" type="radio"/> 48	<input checked="" type="radio"/> 48
-30dB	<input type="radio"/> 88.2	<input checked="" type="radio"/> 88.2	<input checked="" type="radio"/> 88.2
-40dB	<input type="radio"/> 96	<input checked="" type="radio"/> 96	<input checked="" type="radio"/> 96
-50dB	<input type="radio"/> 176.4	<input checked="" type="radio"/> 176.4	<input checked="" type="radio"/> 176.4
-60dB	<input type="radio"/> 192	<input checked="" type="radio"/> 192	<input checked="" type="radio"/> 192

Figure 4 – The Sample Rate LEDs operating as the Volume indicator

- Setting the **Output Level** switch on the back panel to **6V** usually gives best results, but this depends on the rest of your system and the size of your room. If the setting is **2V** and the volume is still set below -20dB with most music, ask your dealer about trying some passive attenuators.

Proceed to Step 4.

STEP 4 – Using a System Clock

So far, when using the PCM inputs, the system has been set up to lock to the clock generated by the source. This is the simplest arrangement, but it does not give the best sonic performance due to clock jitter.

If the source equipment can be locked to word clock or the USB interface is selected, the performance can be improved further by adding a *Paganini* Clock to the system as shown in the example below.

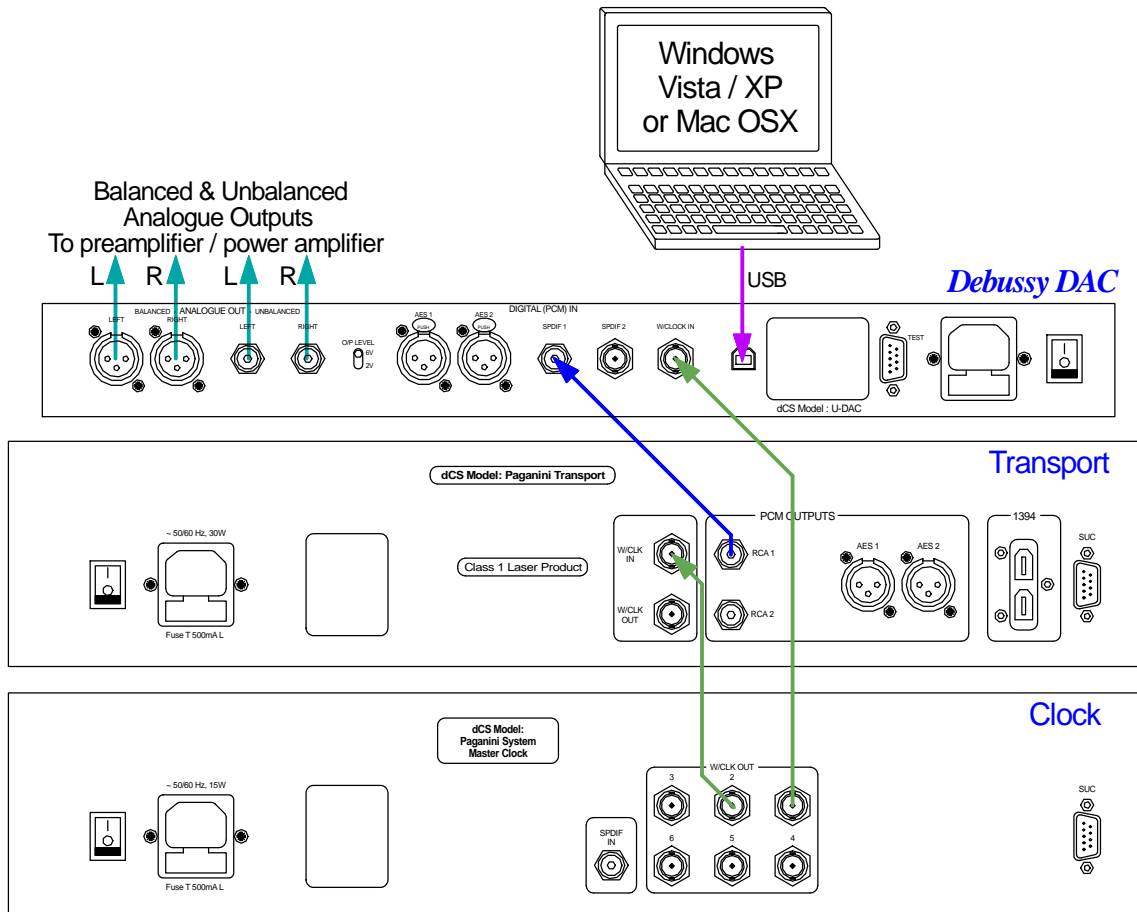

Figure 5 – Using the *Paganini* Transport, Clock and *Debussy DAC* together

- Connect two of the Clock's **W/Clk Outputs** to the **W/Clk Inputs** of the Transport and *Debussy DAC*.
- Use the Clock's **Frequency** button to set the outputs to **44.1kHz**, to suit the CD Transport.

The system will re-lock and un-mute.

Please consult the Clock manual for more information on using a System Clock.

The next step is crucial – sit back and enjoy the music.

FRONT PANEL



Figure 6 – Front panel

POWER Button

To switch on, ensure the rear panel switch is set to **I** and press the **POWER** button (A) on the front panel once. The LED to the left of the **POWER** button will illuminate. Note that the unit cannot be turned on by remote control.

To set the unit to sleep mode, press the **POWER** button once. The LED to the left of the button will dim, the other LEDs will turn off and the analogue outputs will mute, but the unit will remain close to running temperature. Press the button again to return to normal operation.

To switch off completely, hold down the **POWER** button for at least 3 seconds then release it.

VOL+/- Buttons

The digital volume control covers a range from -60dB0 to 0dB0 in 0.5dB steps. Press or hold down the **Vol+** button (B) to increase the volume, press or hold down the **Vol-** button (C) to reduce the volume. The Ring DAC™ circuit has linearity to spare but for best results, set up your system to use a volume setting between -20dB and 0dB for normal listening. While the volume is being adjusted, the Sample Rate LEDs (K) indicate the approximate volume setting in 10dB steps.

MUTE Button

Use the **MUTE** button (D) to mute the analogue outputs. When the unit is muted (either manually or when not locked to a source) the LED to the left of the button illuminates.

FILTER Button

Use the **FILTER** button (E) to select your preferred anti-image filter. The two filters have very similar amplitude responses but different phase responses.

If the indicator to the left of the button is off, the filter applied is a classic sharp filter, with linear phase and pre-ringing. Press the button to change to the alternative filter, which has non-linear phase and no pre-ringing. The indicator illuminates when the alternative filter is selected.

Filter choice is a personal preference and is best done by ear. The choice of filter may depend on the type of music you are listening to. The *Debussy DAC* remembers the last filter selection for every sample rate.

PHASE Button

If the indicator to the left of the PHASE button (F) is off, all analogue outputs will be in absolute phase with the digital data. Press the button to reverse the phase of all outputs - the indicator illuminates to warn of this. This feature is useful for correcting the playback of tracks that have been recorded in reverse phase.

INPUT button

Press the **INPUT** button (G) repeatedly to cycle through the available digital inputs, the selected input will be shown by the input indicators (J). The sequence is:

USB, AES 1, AES 2, AES1 + AES 2 (Dual AES), SPDIF 1, SPDIF 2, USB, etc...

Word Clock Indicator

The **W/Clock** indicator (H) will be off unless activity is detected at the **W/Clock In** connector.

If a word clock signal is detected and it is at a frequency compatible with the audio data sample rate, the *Debussy DAC* will lock to word clock and the indicator will illuminate. The table below shows compatible combinations.

Word Clock Frequency	Data Sample Rate
44.1 or 88.2kHz	44.1, 88.2 or 176.4kS/s
32, 48 or 96kHz	32, 48, 96 or 192kS/s

If activity is detected but the signal is not recognisable or is at the wrong frequency, the unit will lock to the data stream instead and the **W/Clock** indicator will flash to warn of this.

Remote Control Receiver

The unit accepts IR commands in RC5 format, either from a *dCS* remote or a programmable remote which has been loaded with the correct command codes. Aim the remote control handset towards the receiver (I) for best sensitivity.

If you wish to program your own remote, the command codes are as follows.



Use these command codes only if you agree to be bound by this DISCLAIMER

dCS cannot accept responsibility for problems of any kind that may arise from the use of these remote control codes, cannot offer technical support in its use to installers or customers and cannot undertake to add extra features. If you need assistance, please consult an experienced A/V installer.

All codes are in **decimal**. For the DAC functions, the category code is **13**.

Function	Code
Volume +	16
Volume -	17
Toggle Filter	14
Toggle Phase	9
Toggle Mute	13

Function	Code
Select AES 1	3
Select AES 2	4
Select Dual AES	32
Select SPDIF 1	1
Select SPDIF 2	6
Select USB	2

Function	Code
Next input	27
Previous input	28
Wake	42
Sleep	41
Power off	43

The *Debussy DAC* employs a USB HID interface, which allows control of some Media Player functions. These commands depend on the behaviour of the streaming software, which is beyond our control. At the time of writing, most streaming software does not handle the Fast forward or Fast reverse commands well.

For the Media Player functions, the category code is **20**.

Function	Code
Play / Pause	53
Previous track	33
Next track	32
Fast forward	52
Fast reverse	50

Input Indicators

In normal use, one of these indicators (J) illuminates to indicate the selected input. For Dual AES, both **AES 1** and **AES 2** indicators illuminate. If the *Debussy DAC* is not receiving data through the selected input, the indicator will flash.

Sample Rate Indicators

The column of sample rate indicators (K) remain off when the unit is not locked. When the unit locks to incoming digital data, the indicator for the detected sample rate will illuminate.

When the volume is adjusted, the function of these indicators changes to show the volume setting in 10dB steps, see the table below. 5 seconds after the last volume adjustment, they display the sample rate once more.

	-60dB	-50.5 ~ -59.5dB	-40.5 ~ -50dB	-30.5 ~ -40dB	-20.5 ~ -30dB	-10.5 ~ -20dB	-0.5 ~ -10dB	0dB
0dB	○ 32	○ 32	○ 32	○ 32	○ 32	○ 32	○ 32	● 32
-10dB	○ 44.1	○ 44.1	○ 44.1	○ 44.1	○ 44.1	○ 44.1	● 44.1	● 44.1
-20dB	○ 48	○ 48	○ 48	○ 48	○ 48	● 48	● 48	● 48
-30dB	○ 88.2	○ 88.2	○ 88.2	○ 88.2	● 88.2	● 88.2	● 88.2	● 88.2
-40dB	○ 96	○ 96	○ 96	● 96	● 96	● 96	● 96	● 96
-50dB	○ 176.4	○ 176.4	● 176.4	● 176.4	● 176.4	● 176.4	● 176.4	● 176.4
-60dB	○ 192	● 192	● 192	● 192	● 192	● 192	● 192	● 192

Figure 7 – The Volume indicator ranges

Factory Reset

To reset the unit to factory defaults, hold down the **Vol+** and **Vol-** buttons together at power-on until ALL the LEDs start flashing, then release both buttons. This will reset the unit as follows.

Volume	-30dB
Mute	Not muted
Filter	Sharp filter

Phase	Normal
Input	USB

REAR PANEL



Figure 8 - Rear Panel

Analogue Outputs

The unit features separately buffered **Balanced Outputs** (N) on XLR connectors and **Unbalanced Outputs** (O) on RCA connectors. The **Balanced Outputs** should be connected to true balanced inputs only. If your preamplifier / power amplifier has unbalanced inputs (even if the inputs are on XLR connectors), please use the **Unbalanced Outputs** instead.

Output Level Switch

The **O/P Level** switch (P) sets all outputs to either **2V** rms or **6V** rms at full scale. When you set up your system, choose the Output Level setting that gives a comfortable listening level with the **Volume** set between **-10dB** and **-20dB**. The difference between the two settings is 9.5dB.

AES Digital Inputs

The **AES1** and **AES2** inputs (Q) can be used individually at 32, 44.1, 48, 88.2 or 96kS/s. If both inputs are connected to a Dual AES source and **AES 1 + AES 2** is selected, they can be used together as a Dual AES pair at 88.2, 96, 176.4 or 192kS/s.



For Dual AES mode to work correctly, the source must actually generate Dual AES data, not just single AES on 2 connectors (which gives a mono output)!

Dual AES is available from dCS Upsamplers and some sound cards.

SPDIF Digital Inputs

The unit features 2 co-ax SPDIF inputs (R) on RCA phono (**SPDIF 1**) and BNC connectors (**SPDIF 2**). Each input will accept data at 32, 44.1, 48, 88.2 or 96kS/s.

Word Clock Input

The **W/Clock In** connector (S) will accept standard word clock from the source equipment or a master clock at 32, 44.1, 48, 88.2 or 96kHz.



The clock frequency **MUST** be an exact multiple of the data rate (see page **15**), otherwise the system will not lock to word clock.

The source **MUST** be locked to the same clock unless the USB interface is selected, otherwise the system will not be synchronised and periodic clicks will be heard on the outputs.

Word clock is used for synchronisation only, it does not carry digital data.

USB Interface

The **USB** interface on a 'B' type connector (T) will accept PCM data at up to 24 bits / 96kS/s from a Windows™ PC, Apple Mac™ or sound server equipped with a USB interface. This interface operates in asynchronous mode, which makes the *Debussy DAC* immune to clock jitter from the computer / sound server. The *Debussy DAC* either uses its own internal clock or locks to the system clock connected to the **W/Clock** input. Feedback through the USB cable to the computer controls the rate of data delivery.



We have tested this interface with several common formats running on Windows™ Vista, Windows™ XP and Apple Mac™ OSX with various PCM streaming programs but we cannot accept responsibility for correct operation with all source devices, operating systems or software.



The **USB** interface is designed to work with a computer or sound server. Nothing useful will happen if you connect the interface directly to an MP3 player or a flash stick.

Label

The label (U) states the unit's serial number and the nominal voltage to which the unit is set. It is important to quote the serial number if you need assistance.

TEST Connector

The **TEST** connector (V) is an RS232 interface, primarily used to remotely control the unit during automated testing. Please contact *dCS* for information about using this interface with a household automation system. Note that we recommend using infra-red remote control instead.

Mains inlet

Power is connected via a standard IEC320 connector (W), protected by a fuse (X) and isolated by a 2-pole power switch (Y).

REMOTE CONTROL



Hold down the **Sleep** button for 2 seconds to set the DAC to sleep mode. Press the **Sleep** button again to return to normal operation.

In Sleep mode, press the **OFF** button to turn the DAC off.

The **Filter** buttons changes the filter setting when locked to a source.

The **Input +** and **Input -** buttons cycle through the digital inputs.

The **Vol+** and **Vol-** buttons adjust the Volume.

The **Mute** button turns the Analogue Outputs off and on.

(The other buttons on this handset are for use with other models.)

When the DAC is completely off (not just in sleep mode), press the front panel **Power** button to turn it on. You cannot use the Remote Control for this. The **OFF** button will only operate if the system is in sleep mode.

SPECIFICATION

Converter type	5-bit, 2.822 or 3.07MS/s oversampled, <i>dCS Ring DAC</i> TM topology. All data is oversampled to this format before conversion to analogue.												
Digital inputs	<p>USB interface on a B-type connector, will accept up to 24 bit PCM at 32, 44.1, 48, 88.2 or 96kS/s. Operates in asynchronous mode.</p> <p>2x AES/EBU on 3-pin female XLR connectors. Each will accept PCM at 32 - 96kS/s up to 24 bits, OR as a Dual AES pair at 88.2, 96, 176.4 or 192kS/s up to 24 bits.</p> <p>2x SPDIF on 1x RCA Phono and 1x BNC connectors. Each will accept PCM at 32, 44.1, 48, 88.2 or 96kS/s up to 24 bits.</p>												
Clocking	Word Clock Input on 1x BNC connector, accepts standard word clock at 32, 44.1, 48, 88.2 or 96kHz. The data rate can be the same as the clock rate or an exact multiple (0.5x, 1x, 2x, 4x) of the clock rate. Sensitive to TTL levels.												
Frequency response (set to Sharp Filter)	<table> <tr> <td>Fs = 32kS/s</td> <td>+0.1/-0.5dB, 10Hz to 15kHz</td> <td></td> </tr> <tr> <td>Fs = 44.1 or 48kS/s</td> <td>+/-0.1dB, 10Hz to 20kHz</td> <td></td> </tr> <tr> <td>Fs = 88.2 or 96kS/s</td> <td>+/-0.1dB, 10Hz to 20kHz</td> <td>-3dB @ >38kHz</td> </tr> <tr> <td>Fs = 176.4 or 192kS/s</td> <td>+/-0.1dB, 10Hz to 20kHz</td> <td>-3dB @ >67kHz</td> </tr> </table>	Fs = 32kS/s	+0.1/-0.5dB, 10Hz to 15kHz		Fs = 44.1 or 48kS/s	+/-0.1dB, 10Hz to 20kHz		Fs = 88.2 or 96kS/s	+/-0.1dB, 10Hz to 20kHz	-3dB @ >38kHz	Fs = 176.4 or 192kS/s	+/-0.1dB, 10Hz to 20kHz	-3dB @ >67kHz
Fs = 32kS/s	+0.1/-0.5dB, 10Hz to 15kHz												
Fs = 44.1 or 48kS/s	+/-0.1dB, 10Hz to 20kHz												
Fs = 88.2 or 96kS/s	+/-0.1dB, 10Hz to 20kHz	-3dB @ >38kHz											
Fs = 176.4 or 192kS/s	+/-0.1dB, 10Hz to 20kHz	-3dB @ >67kHz											
Residual noise	Better than -110dB0, 20Hz - 20kHz unweighted.												
Spurious responses	Better than -100dB0, 20Hz - 20kHz.												
L-R crosstalk	Better than -80dB0, 20Hz - 20kHz.												
Output levels	2V rms or 6V rms on all outputs for a full-scale input, set by the Output Level switch on the rear panel.												
Balanced outputs	1 stereo pair on 2x 3-pin male XLR connectors (pin 2 = hot, pin 3 = cold). These outputs are electronically balanced and floating, the signal balance ratio at 1kHz is better than 40dB. Output impedance is 3Ω, maximum load is 600Ω (a load of 10kΩ or more is recommended).												
Unbalanced outputs	1 stereo pair on 2x RCA Phono connectors. Output impedance is 52Ω, maximum load is 600Ω (a load of 10kΩ or more is recommended).												
Size and weight	<p>445mm (17.6") W x 392mm (15.5") D x 65mm (2.6") H including feet. Allow extra depth for cable connectors. Allow space for air flow around the unit.</p> <p>Weight 8.8kg (19.4lbs).</p>												
Power requirements	<p>Internally set to either 100, 115/120, 220 or 230/240V A.C., 49 – 62Hz.</p> <p>Power consumption: 19W typical, 25W maximum.</p>												

These specifications are subject to change without notice.

MAINTENANCE AND SUPPORT

Service and Maintenance

dCS audio products are designed not to need regular maintenance, and contain no user serviceable parts apart from the mains fuse. If your unit is damaged in any way, please contact your dealer.

Replacing a Blown Mains Fuse

There is a mains fuse below the power inlet, accessible from the outside of the unit. If the fuse blows, it may be changed by the user. The current consumption of the unit is very low, so it only blows if power surges occur, or there is a fault in the unit. Usually power surges cause no other damage, but if the fuse blows repeatedly on replacement, some other damage will have been done and the unit will need to be repaired.

Fuse type: 20mm x 5mm T0.5 amp L fuse



If the fuse should fail, it is essential that it is replaced with one of the same type and rating. Failure to do so could result in damage to the unit, risk of fire or electric shock and will invalidate the warranty.

Referring to the diagram below, remove the power cable, use a small flat bladed screwdriver to pry up the tab on the fuse carrier (A) and pull it out. Push the blown fuse out of the clip in the carrier (B) and dispose of it. Fit a new fuse in the clip (C) and push the carrier back into the unit so that it clicks home. Spare fuses are provided with the unit.

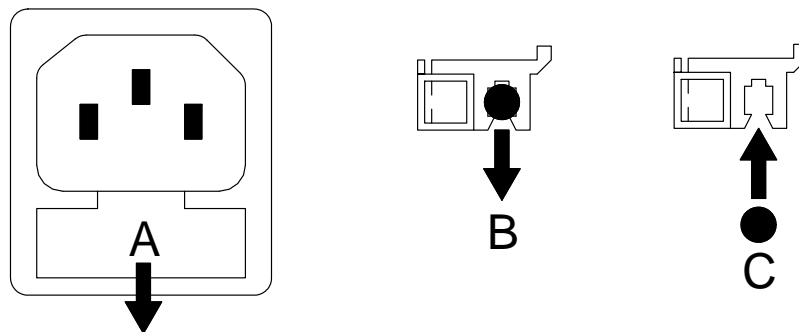

Cleaning the case

The front panel of your dCS equipment is machined from very high grade aluminium. Great care has been taken to create the finish of the aluminium throughout the engineering process from the raw solid material to the finished piece.

To remove loose dust or finger marks from the case, we recommend that you use a clean, dry, lint-free cloth.

To restore the finish on the front panel, we recommend applying small quantities of a lanolin based cleaner, using a clean, dry, lint-free cloth and then wiping off. Do not allow lanolin to collect around the buttons.

Small amounts of glass cleaner containing ammonia may be used to clean other surfaces, but avoid spraying onto the connector contacts.

Limited Warranty

General

dCS warrants this product against defects in materials and workmanship for a period of 3 years from the date the unit was originally shipped from dCS. During the warranty period, dCS will repair or, at our absolute discretion, replace a faulty product. Warranty repairs must only be carried out by dCS or our authorised service agents. Please contact your dealer if your unit requires service.

Your dealer should have completed on your behalf an **Owner Registration** form at the time of sale and returned it to dCS. On receipt of the Owner Registration form, dCS will add your contact details to our customer database. dCS will use this information for warranty purposes only, we will not contact you directly for reasons relating to sales and marketing.

This warranty applies to the original owner.

Warranty Exclusions

The Warranty does not cover wear and tear.

The Warranty on this product will be void if:

- the product is misused in any way.
- any unauthorised modifications or repairs are carried out.
- the product is not used in accordance with the Operating Conditions stated in this manual.
- the product is serviced or repaired other than by dCS or our authorised service agents.
- the product is operated without a mains earth (or ground) connection.
- the unit is returned inadequately packed.

dCS reserve the right to apply a service charge if a product returned for warranty repair is found to be operating correctly, or if a product is returned without a returns number being issued.

This warranty covers parts and labour only, it does not cover shipping charges or tax/duty.

Our dealers or distributors are NOT authorised to extend the terms of this warranty, dCS cannot accept responsibility for any attempt to do so.

Products re-sold by dCS on a "used" basis may be subject to reduced warranty terms.

Obtaining Service

Should you encounter a problem, contact your authorised dCS dealer for advice, quoting the model, the serial number, software version number, and giving a detailed description of the fault. Your dealer will advise you fully on actions that need to be taken. When returning a unit, the original packaging should be used to avoid transit damage. Replacement packaging sets may be purchased from dCS.

During the Warranty period, there will normally be no charge for parts or labour.

Operating Conditions

- The supply voltage must remain within +/-10% of the A.C. voltage specified on the back panel.
- The supply frequency must be in the range 49Hz to 62Hz.
- Ambient temperature range: 0°C (32°F) to 40°C (104°F), non-condensing.
- Do not install the unit near heat sources such as radiators, air ducts, power amplifiers or direct strong sunlight.
- If in doubt, the easy test is – the unit is happy to work anywhere a human is.

Software

Which Software Issue is loaded?

The *Debussy DAC* does not have a display, but if the USB port is connected to a computer, you can find the software issue in the USB device descriptor for firmware version. To do this:

Windows XP™: Go to **Start > Control Panel > System > Hardware > Device Manager > Sound, Video and Game Controllers**. Double click on **USB Audio Device**, select the **Details** tab and choose **Hardware Ids** from the drop-down box. The first line of text that appears will include the software issue prefixed by **Rev_**. For example, **Rev_0103** in the picture below indicates the software issue is 1.03.

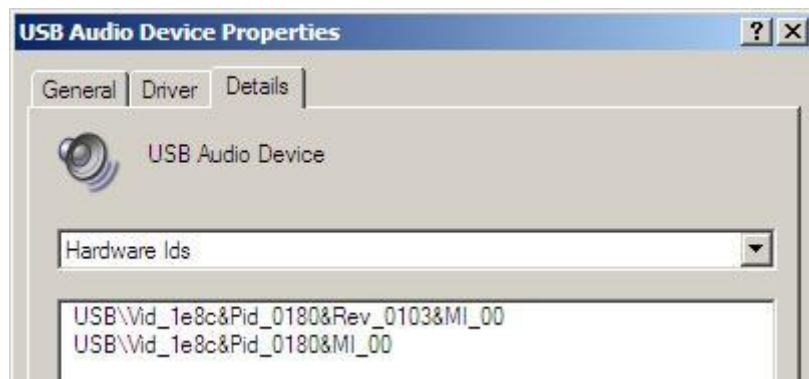

Windows Vista™ / Windows 7™: Go to **Start > Control Panel > System > Device Manager > Sound, Video and Game Controllers**. Double-click on **dCS Debussy**, go to **Details** and select **Hardware Ids** in the **Property** box. The software issue will appear among the text in the **Values** box, prefixed by **REV_**. For example **REV_0100** indicates software issue 1.00.

Mac™ OSX: Open **Finder. Menu Bar > Go > Utilities > System Profiler**. Now go to **Hardware > USB > USB Bus > dCS Debussy**. The revision will be the software issue.

Updating the Software

The CD Update feature allows you to load new software into your system from any STANDARD CD player or transport. Note that some non-Red-Book CD transports change the digital data and cannot be used to download new software. The unit may be updated by streaming the update file via the USB interface from a computer set to give bit-perfect 16-bit output.

The update procedure is deliberately not described here. When an update is available, please follow the instructions supplied with the update disc carefully.

If the selected input is NOT receiving CD format data (16 bits at 44.1kS/s), CD Updating is not possible and the update will not start. Use the front panel controls during an update as the remote control may not operate.



If you start an update unintentionally or when the system is not correctly set up, switch off the unit at the back panel switch, wait 10 seconds, then switch on again.

Software History

dCS products make extensive use of software configurable chips – FPGAs and DSPs. This gives us the ability to update our products to add extra features, update digital interface standards or make performance improvements by loading new software. Occasionally, a hardware upgrade may be necessary also to increase the “capacity” of the electronics, add extra connectors or extra front panel controls.

Please note that not all software updates make an earth-shattering change. You should have a clear idea of what you expect to gain before updating to the latest issue. We recommend that you keep your software up to date. Check the dCS web-site for the latest software updates.

This manual is for *Debussy DAC* software version 1.0x.

- Issue 1.00 - The first issue.

If you need more help

In the first instance, you should contact your dealer. If they cannot resolve the issue, please contact your national distributor.



dCS, our dealers and distributors cannot accept responsibility for I.T. support issues. In such cases, please ask the computer or software vendor for advice.

Manufactured by:

Data Conversion Systems Ltd.
Unit 1, Buckingham Business Park,
Anderson Road,
Swavesey,
Cambridgeshire. CB24 4AE
UK

www.dcsLtd.co.uk

This user manual may be downloaded free of charge from our web-site.
A bound copy of this manual may be ordered from dCS.